

5R SERIES



Compact can do more



COMPACT CAN DO MORE

Compact has evolved. Brimming with power, and loaded with features for versatility and comfort, the new 5R is in a class by itself. This is the tractor for all you do, and everything you've always wanted to.

Finally, there is a light and nimble tractor that also lets you handle all your heavy loads – behind you and in front of you. Built for ultimate versatility, the 5R can easily be fitted with an R-Series front loader, and is equally at home on the road and in the field. This tractor means business: fuel efficient performance at a level of comfort and ease of use that is focused on getting things done – more of them, faster, better.





Contents

- Introduction 2
- Overview 4
- Front loaders 6
- Versatility 10
- Engines 12
- Transmissions 14
- Cab & control concepts 16
- Ride comfort & stability 20
- Hydraulics, hitches & PTO 22
- Specifications 24

Great for front loader work

Electric joystick with reverser and gear shifting, 117 l/min PFC, dedicated JD Click&Go loaders attach with superior ease

Superior visibility

The new low hood, panorama front windshield without bely bar, and the panorama roof bring amazing visibility to the new 5R cab

Extra manoeuvrable

The short 2.25 m wheelbase results in an incredibly tight 3.75 m turning radius with the front loader attached

Compact robustness

With a maximum permissible weight of 8.6 tons, the new 5R's 4.3 tons of payload represent a whopping 48% increase over the previous series. Now the new 5R could even carry another 5R!

Outstanding comfort

The 5R features truly premium specs – front axle suspension (auto, lockable and adjustable), cab suspension and a premium seat

1

2

3

4

5

Many applications, one tractor

Creating opportunity is the lifeblood of every business. Doing more with less frees up resources that can be used to improve and achieve. The 5R is your tractor for that.

For the new 5R, we've pulled together premium features that used to be available only in much larger models. And packaged them into one incredibly agile tractor with the power to move mountains – and to give your business a boost towards greater productivity and more opportunity.



Great for transport

10 hp Transport Power Management (TPM), full speed at 1,750 rpm, auto clutch, cruise control, auto mode, two start off gears

Great in the field

Up to 8 PowerShift gears with 12 gears in the 4-12 km/h working range, 8% power bulge, up to 5,300 kg lift capacity, group 44 rear tires, iTEC basic, 5RN narrow model

Total ease of use

Intuitive controls, universal John Deere tractor user experience – CommandARM, new right hand console, EH SCVs, E-rear hitch, easy cab entry and egress, corner post PDU+ display

Fuel efficient

Diesel only, ECO function (1,750 rpm), 287 g/kWh* diesel only fuel consumption

6

7

8

9



BUILT TO LIFT

Always a perfect match, tractor, loader and implements are designed and built for each other. Get the 5R with the 543R or 603R front loaders and take advantage of the efficient ease of use only our fully integrated design can deliver.



Underslung levelling link

The ingenious geometry of our front loader linkage brings several practical advantages. Because the levelling link is underslung it cannot impair the operator's view. It also conveys more power along the loader shafts, provides easy access for servicing and allows greater steering angles.



Automatic Mast Latch

Mounting our front loaders could not be quicker, safer or more convenient thanks to the self-correcting floating system of the built-in automatic mast latch. Separating tractor and loader is just as easy. Integral to the click & go design, the automatic mast latch comes standard with R series front loaders.



Automatic Implement Latch

Whether you're working with buckets, forks, grapples, bale spikes or elevators, our auto latch system lets you automatically lock and unlock implements with the conveniently located release handle. Integral to the click & go design, the automatic implement latch comes standard with R series front loaders.

TWO SELF-LEVELLING OPTIONS

BUILT FOR THE 5R

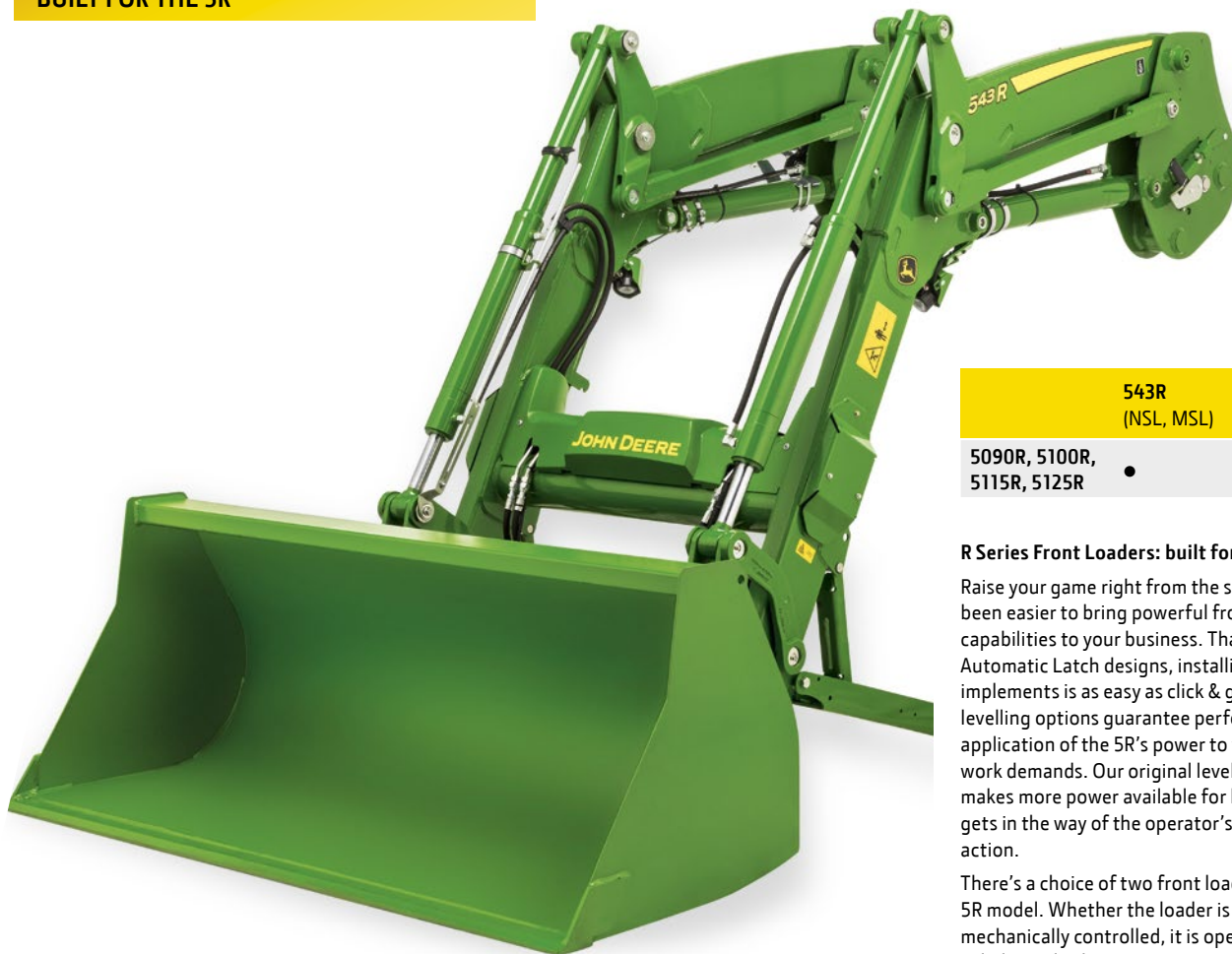

	543R (NSL, MSL)	603R (NSL, MSL, HSL)
5090R, 5100R, 5115R, 5125R	•	•

R Series Front Loaders: built for the 5R

Raise your game right from the start. It has never been easier to bring powerful front loader capabilities to your business. Thanks to our Automatic Latch designs, installing the loader and implements is as easy as click & go. Two self-levelling options guarantee perfectly balanced application of the 5R's power to whatever your work demands. Our original levelling link design makes more power available for lifting and never gets in the way of the operator's view of the action.

There's a choice of two front loaders sizes for each 5R model. Whether the loader is electronically or mechanically controlled, it is operated by a dedicated valve.



Loader suspension

The smooth operation of your John Deere tractor can be enhanced with our front loader suspension unit. Its effective damping protects the material you are handling as well as your tractor, and improves operator comfort on the road. It can be activated/deactivated via the suspension button on the joystick of an M-LCV equipped tractor, or via the electronic joystick on E-LCV equipped tractors.



Loader lights

Purpose-built John Deere loader lights provide the consistent and reliable illumination that you need when working with a front loader in darkness or poor visibility.



Easy-fit

Every 5R tractor can be fitted with a loader-ready package ex-works, including mounting frames, hood protection, in cab joystick and all the internal electrical and hydraulic connections.

BORN TO FRONT LOAD

Your front loader requirements were integral to the design process for the 5R. A number of crucial engineering decisions were made specifically to make sure that the new 5R is one of the best front loader tractors for your money.

What good is a great front loader, if it can't get to the load? With its short 2,250 mm wheelbase, reduced overall length, and best-in-class turning radius of 3.75 m, the 5R is designed to go to wherever your load may be. Tight spaces are the 5R's specialty.

LOW CENTRE OF GRAVITY

BETTER BALANCE

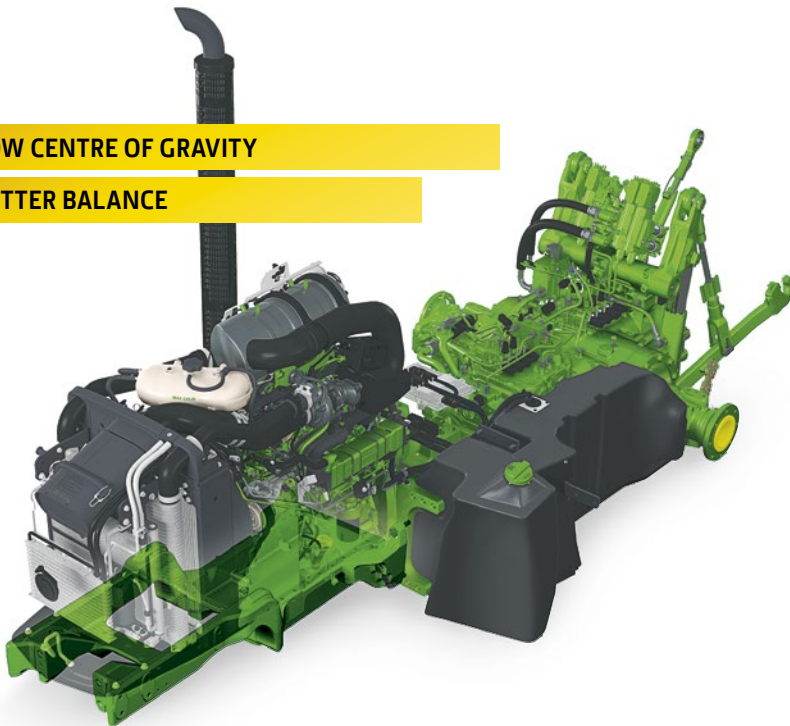

The frame you can depend on

The super strong integrated casting frame of the 5R gives you the rock solid foundation from which to master even the most challenging front loader tasks. The curved frame puts the centre of gravity low, so that you'll always have superior balance, no matter what terrain you are on.



Take command

Two great choices for easier, safer and more efficient front loader work. The CommandQuad and the Command8 transmission options both bring you enhanced clutch-less auto-shifting, and the PowrReverser simplifies working with a front loader with clutch-less forward/reverse direction changes.



The best view in the business

Form follows function – it’s one of those immutable engineering truths. And it’s what drove the visibility design of the 5R. The panorama roof, the panoramic windshield, and the new low hood open up your field of vision and let you focus your attention on your front loader tasks like never before.



More power ahead

Get the power and control you need for any front loader job. The 5R’s advanced Pressure and Flow Compensated (PFC) hydraulic system can produce a flow of up to 117 l/min. Another first in this class of tractor.

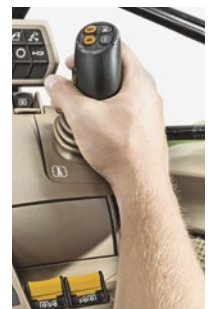
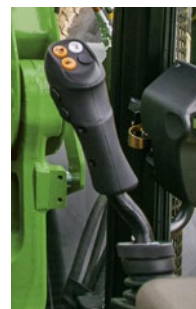

Joystick options

Mechanical and electrical joysticks can be mounted on either the armrest, or the CommandARM. The electronic joystick provides up to 5 functions, including GSS, reversing, gear shifting and 3rd and 4th independent hydraulic functions.

BE GREAT, NOT BIG

Imagine that you own two amazing tractors. One is compact, light and nimble. You can get it into even the tightest spaces. You love its manoeuvrability. It's light, fuel efficient and incredibly easy to operate. The other tractor is brimming with power, strong, stable, solid. It will lift whatever you put in front of it. Now forget the two tractor idea. The 5R is the one that has it all.

With its compact footprint and a short wheelbase of just 2,250 mm, the 5R is as nimble as they come and will go anywhere you need it to be. We've equipped it with the power to do all the heavy work you'd usually call upon its bigger brothers for. It starts at a light 4.3 t, but punches way above that class – so you can give it all the loader work you've got. Final proof that you don't have to be big to be great.

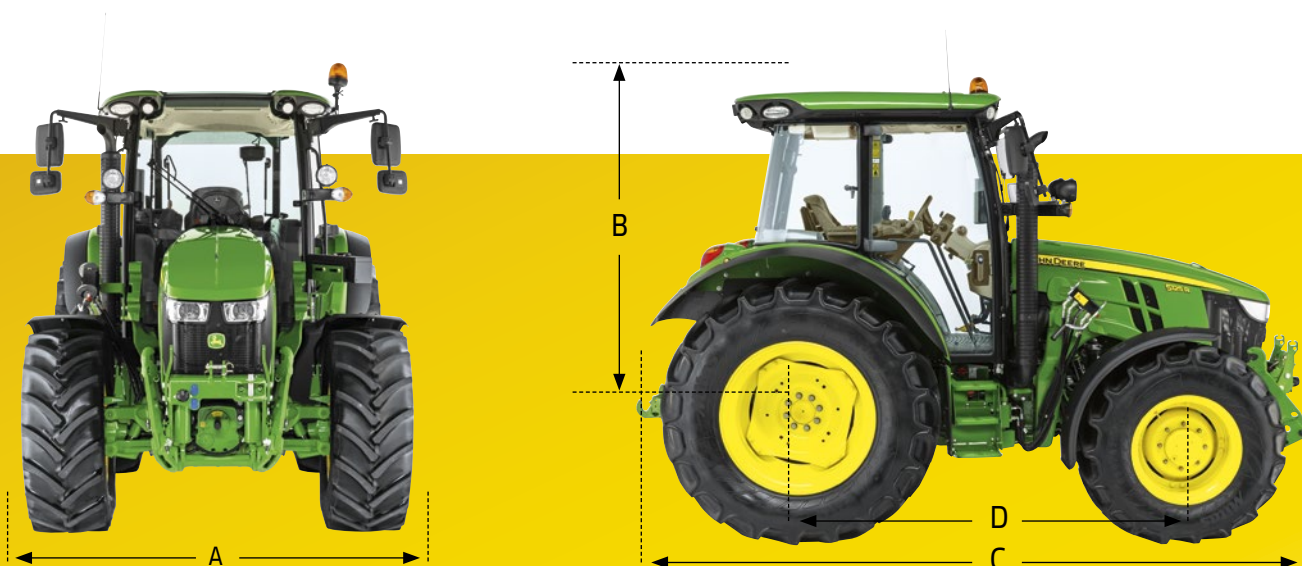

Great in small spaces

If you could express productivity in meters, that number would be 3.75 m. Even with the loader mounting frames and loader connected, the 5R maintains this excellent turning radius. It's perfect for effective front loader work in tight spaces.

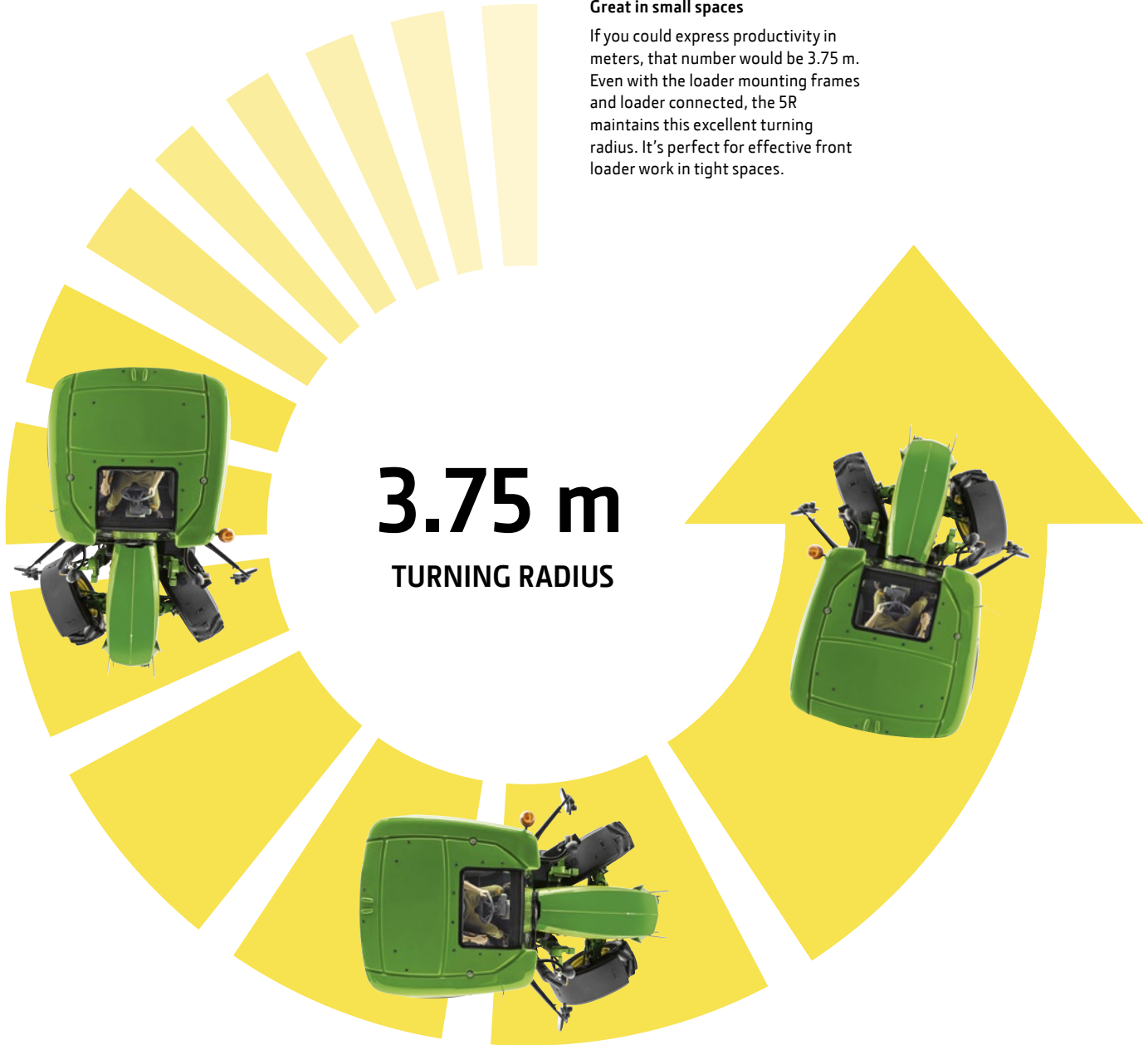

3.75 m
TURNING RADIUS

Dimensions	5R Standard Version	5R Narrow Version
(A) Width	2,150 mm	1,700 mm
(B) Relative height*	1,937 mm	1,937 mm
(C) Overall length	3,653 mm	3,653 mm
(D) Wheelbase	2,250 mm	2,250 mm

*Center of rear axle to top of cab roof

ALL DIESEL, ALL MUSCLE

Get all the power you'll ever need, and still meet Stage IIIb emissions standards. Save big on fuel too. The 5R Series tractor's renowned diesel-only 4.5 l PowerTech PWX engines consumes only around 287 g/kwh. Most other tractors in this segment need more than 300 g/kwh*.

Just add... nothing

No additives required. By combining Cooled Exhaust Gas Recirculation (EGR) technology with an intercooler and Diesel Particle Filter (DPF), Stage IIIB emissions standards are met without the need for any additives.

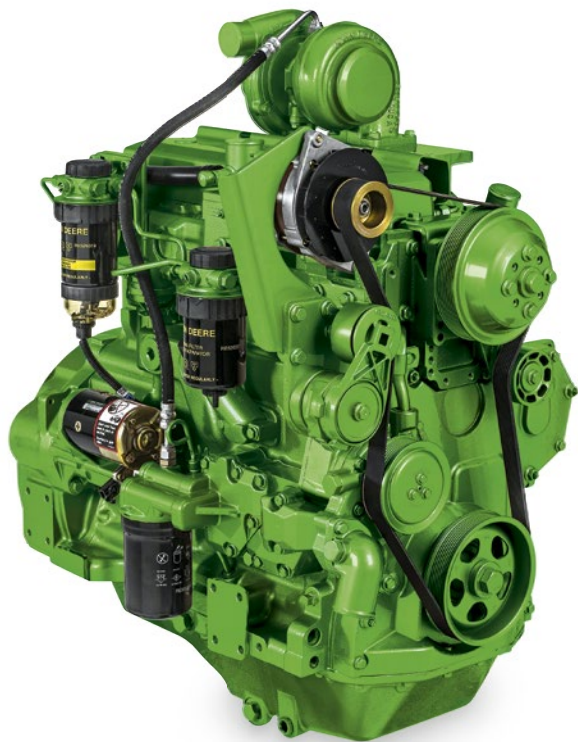

Built for the farm

Like all John Deere power units, the PowerTech PWX 4-cylinder, 4.5 litre High Pressure Common Rail engine was carefully engineered for the demands of agricultural applications. Full speed is reached at just 1,750 rpm. Transport Power Management (TPM) boosts the rated power for on-demand benchmark power density. An extra 10 hp is available on tap in transport situations. Wastegated turbocharging combined with advanced emissions control technology, ensure a long clean life for this engine.

5R Models (Rated Power 97/68EC)

5090R	66.6 kW (90 hp)	(100 hp with TPM)	4-cyl.
5100R	74 kW (100 hp)	(110 hp with TPM)	4-cyl.
5115R	85 kW (115 hp)	(125 hp with TPM)	4-cyl.
5125R	91.9 kW (125 hp)	(135 hp with TPM)	4-cyl.

*Based on internal test conducted by John Deere according to DLG PowerMix standards

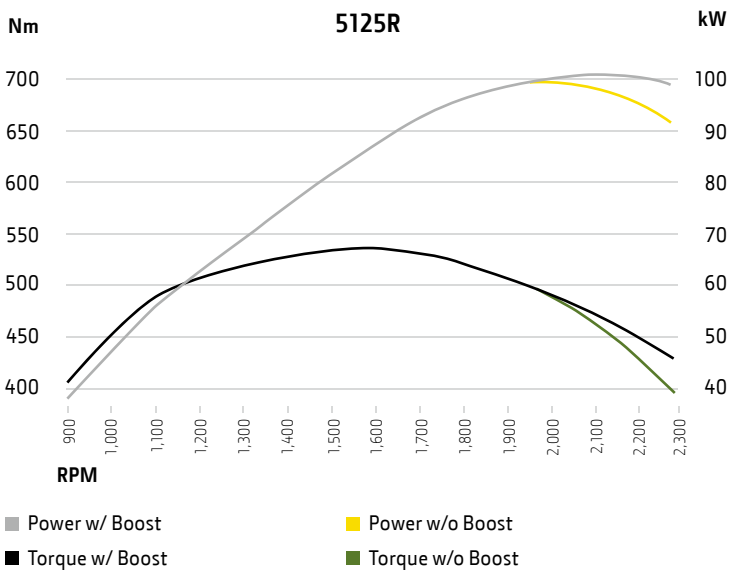

Ultimate power

When nothing short of spectacular will do. The 5125R delivers an impressive 125 hp, and 135 hp with TPM boost.

Superior efficiency

The John Deere 4.5 L PowerTech PWX 4-cylinder engines that power the 5R Series tractors are renowned for their efficiency. Smart technology that's right for our times and your business.

TRANSMISSIONS: CHOOSE PRODUCTIVITY

We give you two distinctive options because only you can decide what's best for your business. Whichever you select will be a solid choice for productivity, fuel efficiency and operator convenience. That's what the new 5R is all about.

Choose between the CommandQuad transmission option with four PowerShift gears (1-4) in four ranges (A-D), and the Command8 transmission with eight PowerShift gears (1-8) in four ranges (A-D). Both options bring you enhanced clutch-less auto-shifting so that you're always in the right gear for the task at hand. Both are built entirely in-house by us, carefully engineered to make you feel like your job just got a whole lot easier.



8 POWERSHIFT GEARS

EASY TO OPERATE



Command8

We see every single unnecessary motion we can remove from your day as a small triumph. The goal is simple: less for you to do, and easier for you to do it. You'll appreciate the intuitive operation with a single control lever, eye-catching orange range buttons, all in a common John Deere Layout. Essential efficiency features such as cruise control, auto clutching, PowrReverser and automatic gear and ranges shifting in Auto Mode, allow you and your tractor to achieve optimal levels of productivity while consuming as little energy and fuel as possible.

	CommandQuad Manual	CommandQuad	Command8
Total number of gears (F/R)	16/16	16/16	32/16
Number of PowerShift gears	4	4	8
Max. speed	40 km/h	40 km/h	40 km/h
Number of ranges	4	4	4
Auto function	N/A	■	■
2 start of gear	■	■	■
2 set speed	–	■	■
Creeper	–	–	□
ECO function	–	–	■

■ Base □ Optional – Not available

You know what you need – it's our job to deliver choices.
Here are yours – productivity guaranteed.



Always optimal

The Command8 transmission ensures that power and torque are always transmitted in the most efficient manner, under any conditions, in all applications.

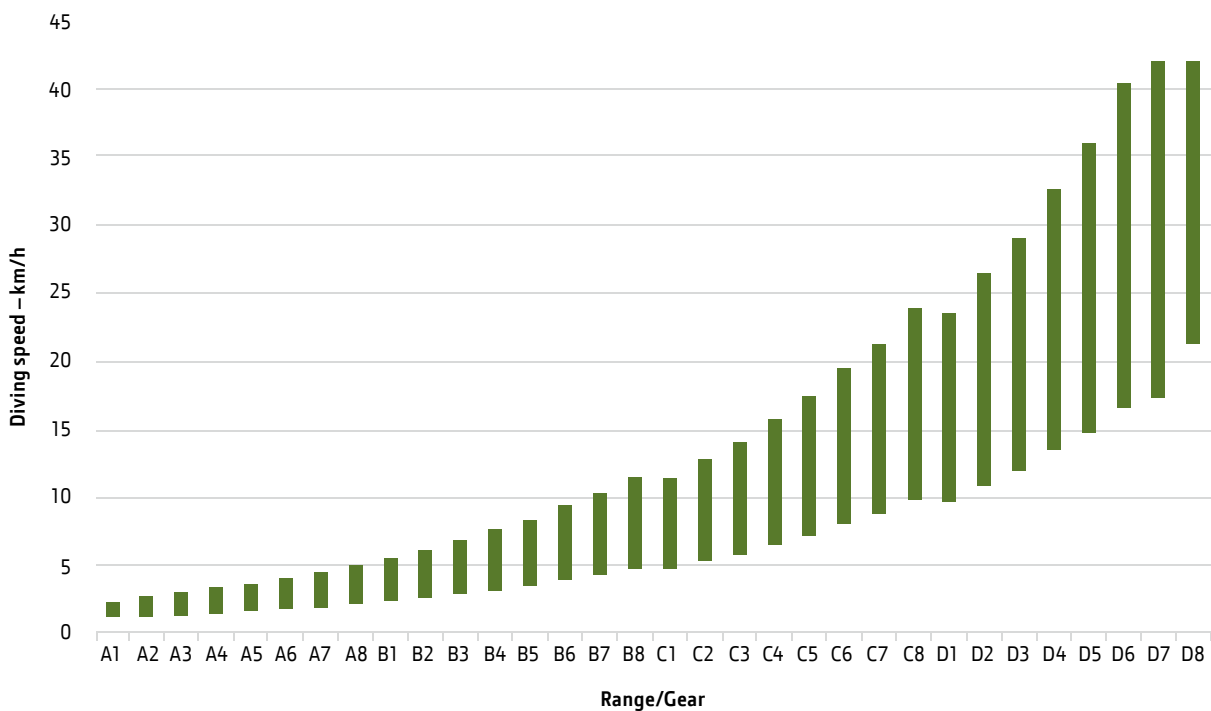



BIG VIEW, ULTIMATE COMFORT

Imagine a workspace that, by its very design helps you do a better job. Where complex tasks are accomplished with intuitive ease. This is the 5R cab – where it is all about making your tractor easier to operate.

Your needs, your choice. Both the 5R's right-hand console and the new CommandARM were designed according to best-practice ergonomic principles and in perfect alignment with the new Primary Display Unit (PDU+) in A-post. There's more glass around and above you, for a completely unencumbered view. All in a premium look and feel that has not been seen in a tractor of this class until now.



In and out with ease

This cab is not just a pleasure to be in, we also made sure that you can get in and out safely and effortlessly. The tilt adjustable steering column lets you find the perfect seating position. A comfy instructor seat is also available.

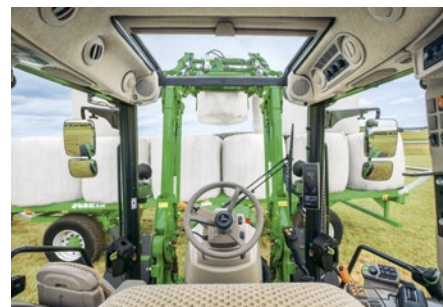

Panorama roof

You'll feel much better about all that weight on your loader with the spacious view through the 5R's panorama roof. See where everything is and where it needs to go.

A lot more front visibility

Having a better view of the action right in front of you is critical in many situations. So we've brought the hood down as low as we could. This low hood design in combination with the optional panorama roof provides an optimum 105 degrees front visibility angle. Perfect for all front loader applications.



Panoramic windshield for maximum visibility

Premium Seat

Comfortable, foldable instructor seat

Wide opening doors for easy entry and egress

Left hand storage compartment



1

2

3

4

5

1

4

3

2

5

New CommandARM

PDU+ (Primary Display Unit) in A post

Multiple transmission options

iTEC Basic

Multiple cup holders and storage areas



At ease, in full control

Better controls mean more control. Make easy work of complex operations and manoeuvres with the CommandARM – an advanced man-machine interface designed for effortless fingertip control and monitoring of all tractor functions. In conjunction with the Primary Display Unit in A-post the CommandARM provides a thoroughly intuitive interface to your 5R. Operate all transmission functionality. Control all SCVs with easy to recognize colour coded fingertip levers. Precision dial

engine speed with the hand throttle, and control rear hitch. It's all about what works for you. Get ready to control your day.

Primary Display Unit (PDU+)

ONE GLANCE, ALL THE INFORMATION



Engine menu

Cruise function, exhaust filter



Hitch menu

Load depth, upper limit, drop rate



Transmission menu

Eco engine speed, reverser ratio



Drop PTO off

Drop to target – PTO not engaged



Drop PTO on

Drop to target – PTO engaged



Load anticipation

Engine speed adjusts for PTO/rear hitch

iTEC

iTec Basic menu

iTEC on/off, and choose functionality



Maintenance menu

Check/control service interval + diagnostics



Display adjustment menu

Display configuration and setup



Instant status

Located on A-post, in direct line of sight, PDU+ shows important messages and warnings about essential tractor functions. It is conveniently operated by a rotary knob on the right hand console or the CommandARM.



New Right Hand Console

PDU+ (Primary Display Unit) in A post

Multiple transmission options

iTEC Basic

Multiple cup holders and storage areas



New Right Hand Console

At a more basic level, you have the option of the 5R's new Right Hand Console – ergonomically designed, with the most essential controls within easy reach for you.

ROCK SOLID COMFORT, ANYWHERE



You'll feel like nothing can ever throw you off balance in the 5R. Stay more alert and productive in the knowledge that your 5R can handle any kind of terrain with aplomb.

It's strong integrated casting frame puts the centre of gravity low and gets you excellent balance and performance even on tricky hillside terrain. Large tires with a diameter up to 1,70 m in the rear bring more muscle to the ground.



Air-suspended seat

For extra comfort, the base air suspension seat is available with a seat heating option.

TAILORED TO YOUR NEEDS

UPPER CLASS COMFORT



Mechanical cab suspension

You will appreciate a ride surprisingly free of unpleasant vibrations and shocks. Over a long day such irritations can be tough to deal with, and cause fatigue that can become a safety and health risk. The maintenance free mechanical cab suspension takes care of all the rough spots and brings you a smooth ride throughout.



Front axle suspension – uncompromising comfort

The arms of the suspended front axle smoothly adapt to changes in terrain for truly outstanding in-field performance. The suspension is lockable for added precision, but can automatically adjust to keep the front axle level with changing loads for rock solid tractor balance. It all adds up to superior ride comfort with maximum functional effectiveness.



FULL POWER, PRECISION CONTROLLED

The advanced hydraulics system of the 5R is all about connecting its skilled operator directly to the implement. No time lost, no power lost, with fine grained control of every motion.

5R tractors are equipped with up to 7 selective control valves, 3 in the mid and 4 in the rear position. The Pressure and Flow Compensated (PFC) hydraulic system is capable of producing a maximum flow of 117 l/min whenever the system loading requires it. Power and control where you need it, when you need it.



BETTER CONTROL

MORE MUSCLE

Better access

Positioned for easy access between the rear pitch rails, the SCV stack groups together up to 4 SCVs, Power Beyond couplers and the Pressure-Free Return circuit valve in one convenient location.



Front hitch and front PTO

We made premium standard on the 5R. The integrated front hitch and PTO make the 5R Series highly versatile in front-implement applications, without costing you anything extra.

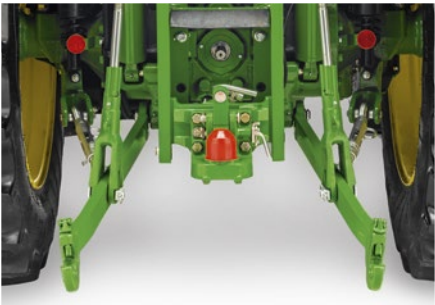

Ultra-sturdy rear hitch

Hook up whatever you need for the job. Built to handle even the heaviest of implements, the super robust rear hitch of the 5R has a maximum lift capacity of up to 5,300 kg*.



Better headland turns with iTEC Basic

Intelligent Total Equipment Control Basic co-ordinates the control of implements when executing headland turns by automatically disengaging PTO, diff lock and 4WD.

*maximum lift capacity at hooks

Specifications

MODEL	5090R	5100R	5115R	5125R
ENGINE PERFORMANCE				
Rated power (97/68EC), hp (kW)	90 (66.6)	100 (74)	115 (85)	125 (91.9)
Rated power with TPM (97/68EC), hp (kW)	100 (74)	110 (81.5)	125 (92.3)	135 (99.2)
Max. power (97/68EC) hp (kW)	92.9 (72)	108.7 (80)	125 (91.9)	135 (99.3)
Constant power range, rpm	2,200-1,650			
Torque reserve, % percentage	36	36	36	33.8
Maximum torque, Nm (at 1500 engine rpm)	393	437	502	534
Rated speed, rpm	2,200			
Manufacturer	John Deere			
Type	PowerTech PWX			
Aftertreatment	EGR – DOC – DPF			
Aspiration	Turbocharger with wastegate			
Cylinders / Displacement	4 / 4.5			
Cooling system	Liquid cooled			
Fuel injection system & control	High pressure common rail system, electronically controlled			
TRANSMISSIONS				
CommandQuad Manual				
16/16 2.3 – 40 km/h – Only manual	•	•	•	•
CommandQuad				
16/16 2.3 – 40 km/h – with Auto function	•	•	•	•
Command8				
32/16 2.3 – 40 km/h – with Auto and ECO function	•	•	•	•
Creeper only with Command8	•	•	•	•
AXLES				
Suspended front axle (option)	•	•	•	•
Engagement front differential lock	Std axle: Limit slip differential – Suspended Front axle: electro-hydraulic			
Engagement rear differential lock	Electro-hydraulic			
Rear axle	Flange axle			
STEERING				
Type	Hydrostatic			
HYDRAULIC SYSTEM				
Type	Open center (OC) or Pressure & Flow Compensated (PFC) system with load sensing function			
Flow at rated engine speed base/option, l/min	96 / 117			
Selective control valves	Up to 4+3			
Power beyond	Optional			
3-POINT HITCH – Rear				
Type	Electronic lower link sensing; load & depth control, infinite mix			
Category	II			
Base Maximum lift capacity at hooks, kg	4,691			
Base Lift capacity through full lift range (OECD 610 mm), kg	2,753			
Option Maximum lift capacity at hooks, kg	5,394			
Option Lift capacity through full lift range (OECD 610 mm), kg	3,080			

MODEL	5090R	5100R	5115R	5125R
3-POINT HITCH – Front, optional				
Type	Front hitch controlled by rear SCV			
Category	II			
Maximum lift capacity at hooks, kg	3,262			
Lift capacity through full lift range at the hooks, kg	2,854			
REAR PTO				
Type	Electro-hydraulically engaged			
FRONT PTO, optional				
Type	Electro-hydraulically engaged			
Engine speed at rated PTO speed (1,000), rpm	2,000			
CAB				
Specifications	Standard or Panorama roof			
Suspension (option)	Mechanical			
Noise level at operator's ear, dB(A)	74			
Display	PDU+			
MISCELLANEOUS				
Pedale lock mode	Std			
Hydraulic trailer brake systems (options)	2 Line			
Pneumatic trailer brake system (option)	2 Line			
CAPACITIES				
Fuel tank (base) l	178			
DIMENSIONS AND WEIGHTS				
Wheelbase, mm	2,250			
Width x Height x Length, mm	2,150 x 2,695 x 3,653			
<i>Measured with flanged axle, up to cab roof, from hood to rear tire and with tires 16.9 R34.</i>				
Minimum Shipping weight, kg	4,300			
Maximum permissible gross weight, kg	8,600			
TIRE SIZES				
Front tire sizes, max. available (diameter in cm)	480/65R24 (126)			
Rear tire sizes, max. available (diameter in cm)	540/65R38 (168)			

Specifications

The American Society of Agricultural and Biological Engineers is an educational and scientific organization dedicated to the advancement of engineering applicable to agricultural, food, and biological systems. Founded in 1907 and headquartered in St. Joseph, Michigan, ASABE comprises 8,000 members in more than 100 countries.



TRACTOR MODEL				5090/5100/5115/5125R		
FRONT TIRE				575/13.6R24		
REAR TIRE				750/16.9R34		
WHEELBASE		(WB)	in / mm	2,250		
PUMP CAPACITY			gpm / lpm	70		
RATED PRESSURE			psi / BAR	2,828/195		
LOADER				543R NSL		
BUCKET				Heavy Duty Bucket 1,850 mm		
BUCKET WEIGHT			lb / kg	600	272	
LIFT CAPACITY @ FULL HEIGHT	MEASURED @ PIVOT		(U)	lb / kg	4,548	2,063
	MEASURED @ 800 mm AHEAD OF PIVOT		(V)	lb / kg	2,948	1,337
LIFT CAPACITY @ 59 in (1.5m) LIFT HEIGHT	MEASURED @ PIVOT		(W)	lb / kg	4,872	2,210
	MEASURED @ 800 mm AHEAD OF PIVOT		(X)	lb / kg	3,642	1,652
BOOM BREAKOUT	MEASURED @ PIVOT		(Y)	lb / kg	5,130	2,327
	MEASURED @ 800 mm AHEAD OF PIVOT		(Z)	lb / kg	3,556	1,613
BUCKET ROLLBACK FORCE	@ MAXIMUM HEIGHT		(VV)	lb / kg	3,633	1,648
	@ 59 in (1.5 m) LIFT HEIGHT		(XX)	lb / kg	5,977	2,711
	@ GROUND LEVEL		(ZZ)	lb / kg	5,655	2,565
MAXIMUM LIFT HEIGHT			(A)	in / mm	145	3,682
CLEARANCE	@ FULL HEIGHT – BUCKET LEVEL		(B)	in / mm	136	3,442
	@ FULL HEIGHT – BUCKET DUMPED		(C)	in / mm	105	2,678
OVERALL LENGTH			(WB+F)	in / mm	183	4,649
DIGGING DEPTH			(H)	in / mm	-4	-102
REACH	@ MAXIMUM HEIGHT		(D)	in / mm	31	776
	@ GROUND – BUCKET LEVEL		(F)	in / mm	94	2,399
BUCKET ANGLES	DUMP ANGLE @ FULL HEIGHT		(E)	degrees	-58	
	ROLLBACK @ GROUND		(G)	degrees	47	
	DUMP ANGLE @ GROUND			degrees	-151	
CYCLE TIMES	LOADER RAISE			sec	4.35	
	LOADER LOWER			sec	3.26	
	BUCKET DUMP			sec	3.30	
	BUCKET ROLLBACK			sec	2.22	

5090/5100/5115/5125R		5090/5100/5115/5125R		5090/5100/5115/5125R		5090/5100/5115/5125R	
575/13.6R24		575/13.6R24		575/13.6R24		575/13.6R24	
750/16.9R34		750/16.9R34		750/16.9R34		750/16.9R34	
2250		2250		2250		2250	
70		70		70		70	
2,828/195		2,828/195		2,828/195		2,828/195	
543R MSL		603R NSL		603R MSL		603R HSL	
Heavy Duty Bucket 1,850 mm		Heavy Duty Bucket 1,850 mm		Heavy Duty Bucket 1,850 mm		Heavy Duty Bucket 1,850 mm	
600	272	600	272	600	272	600	272
3,746	1,699	4,786	2,171	3,964	1,798	4,317	1,958
3,781	1,715	3,287	1,491	3,995	1,812	4,372	1,983
4,599	2,086	5,267	2,389	4,879	2,213	5,029	2,281
4,284	1,943	4,039	1,832	4,579	2,077	4,932	2,237
5,615	2,547	5,725	2,597	5,778	2,621	5,732	2,600
4,612	2,092	4,176	1,894	4,956	2,248	5,201	2,359
3,746	1,699	5,135	2,329	5,282	2,396	5,792	2,627
6,021	2,731	8,913	4,043	8,510	3,860	9,899	4,490
5,668	2,571	9,237	4,190	8,466	3,840	10,992	4,986
145	3,683	148	3,762	148	3,764	148	3,764
136	3,443	139	3,522	139	3,524	139	3,524
106	2,680	108	2,752	108	2,754	108	2,753
183	4,649	196	4,986	196	4,986	196	4,985
-4	-99	-9	-226	-9	-224	-9	-224
30	773	41	1,048	41	1,047	41	1,036
94	2,399	108	2,736	108	2,736	108	2,735
-58		-54		-54		-54	
47		52		52		53	
-100		-143		-99		-143	
4.03		5.1		4.7		4.7	
2.89		3.8		3.5		3.5	
2.22		4.3		3.0		3.2	
2.22		3.0		3.0		1.1	

NOTHING RUNS LIKE A DEERE.

Chances are that when you need us, you need us right then and there. For advice, to solve a problem, for a part.

Reach out, we'll be there with technicians who are all factory trained, ready to go to work for you, using only genuine John Deere parts and products. Our comprehensive PowerGard maintenance plans are designed to keep your equipment running great, and operating costs within your budget. That's our commitment to your peace of mind.

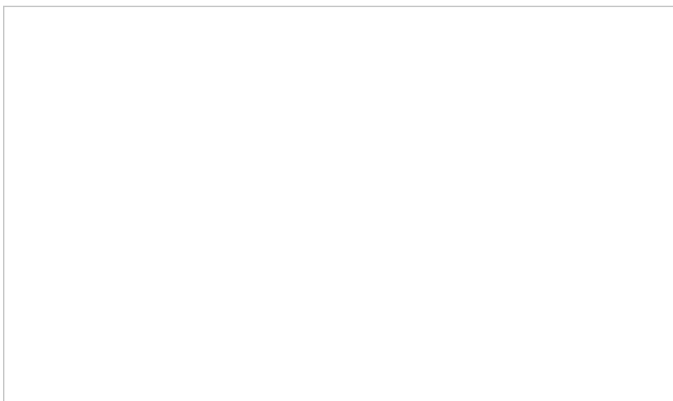

John Deere Financial – A range of finance options as powerful as our products. Contact your John Deere dealer for a comprehensive range of finance options to suit the specific needs of your business. Not available in all countries please consult your local dealer.

This literature has been compiled for worldwide circulation. While general information, pictures and descriptions are provided, some illustrations and text may include finance, credit, insurance, product options and accessories not available in all regions. Please contact your local dealer for details. John Deere reserves the right to change specification and design of products described in this literature without notice. The green and yellow colour scheme, the leaping deer logo and the JOHN DEERE word mark are trademarks of Deere & Company.

JohnDeere.com